

Yoshimatsu's "Pseudo Sonata" Formal Organization in Takashi Yoshimatsu's "Memo Flora"
 Tables and Figures

Table 1-Large-Scale Formal Organization

Section:	Exposition	Development	Recapitulation
Measure:	1-114	115-204	205-269

Table 2-Exposition

Section:	Intro	Primary Theme	Transition	M.C. Effect	TM1	TM2	TM3	E.E.C. Effect	Closing
Measure:	1-23	24-31	32-53	54-55	56-71	72-93	94-105	106	107-114

Table 3-Development

Section:	Pre-Core	Core Part 1	Core Part 2	Core Part 3	Retransition
Measure:	115-120	121-136	137-160	161-188	189-204

Table 4-Recapitulation

Section:	Fusion of P, TR, and S	E.S.C. Effect	Closing
Measure:	205-240	241-244	245-269

Figure 1-Primary Theme *Tonnetz*

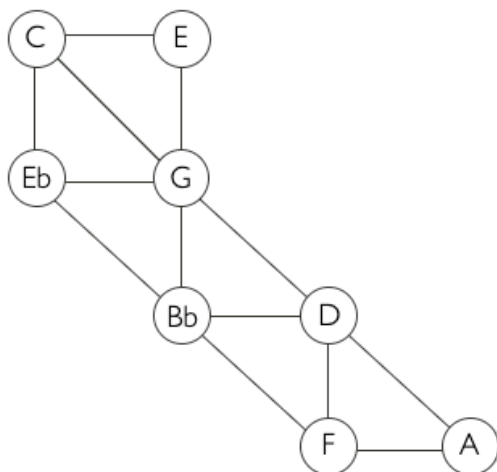

Figure 2-Development, Core Part 1 *Tonnetz*

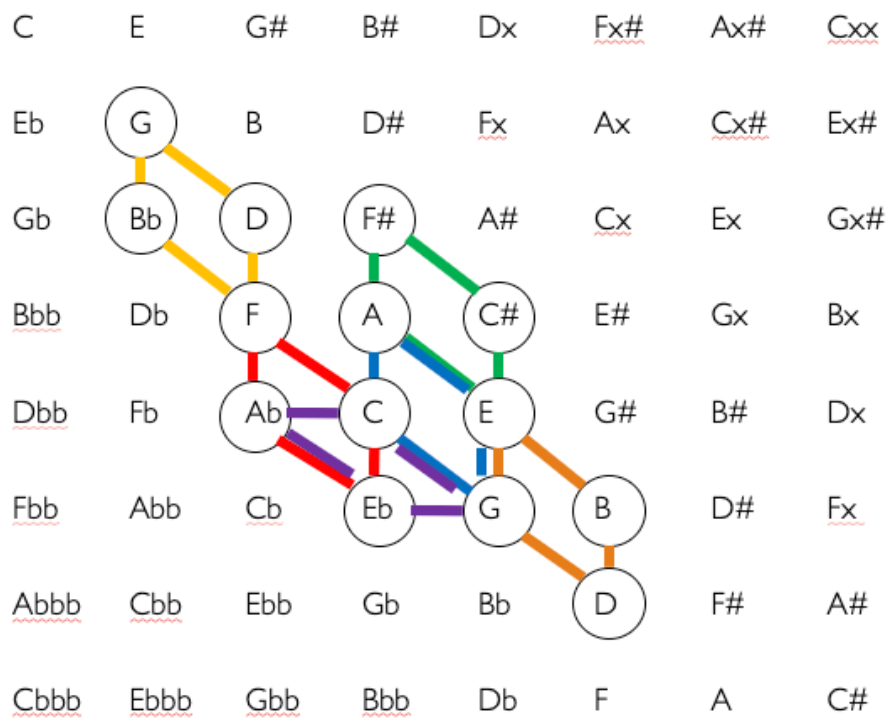

Figure 3-Development, Core Part 2 *Tonnetz*

